

# USER MANUAL OF HALL LANTERN (TRIANGLE)

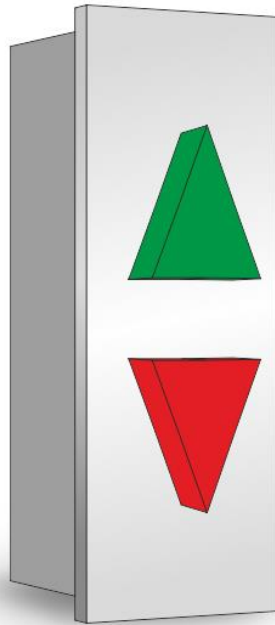

Hall Lantern is mounted in the hallway to provide visual indication that a car is about to arrive, the direction of travel when it leaves.

## **FEATURES/SPECIFICATION:**

- Easy to install - Flush Mount
- Power supply- 24V
- Cost effective
- Triangle shape
- Bright LED colours
- Compact in size -250 X 100 X 60 mm
- Reliable to use
- Increased Durability

## **HOW TO INSTALL:**

### **FOLLOW THE STEPS FOR INSTALL:**

1. Remove the back box of HALL LANTERN.
2. Flush Mount the back box on the suitable place of wall surface.
3. Do connection as per below given connection diagram.
4. And fix the front plate of HALL LANTERN just pushing inside the back box.

**MOUNTING DETAILS:**

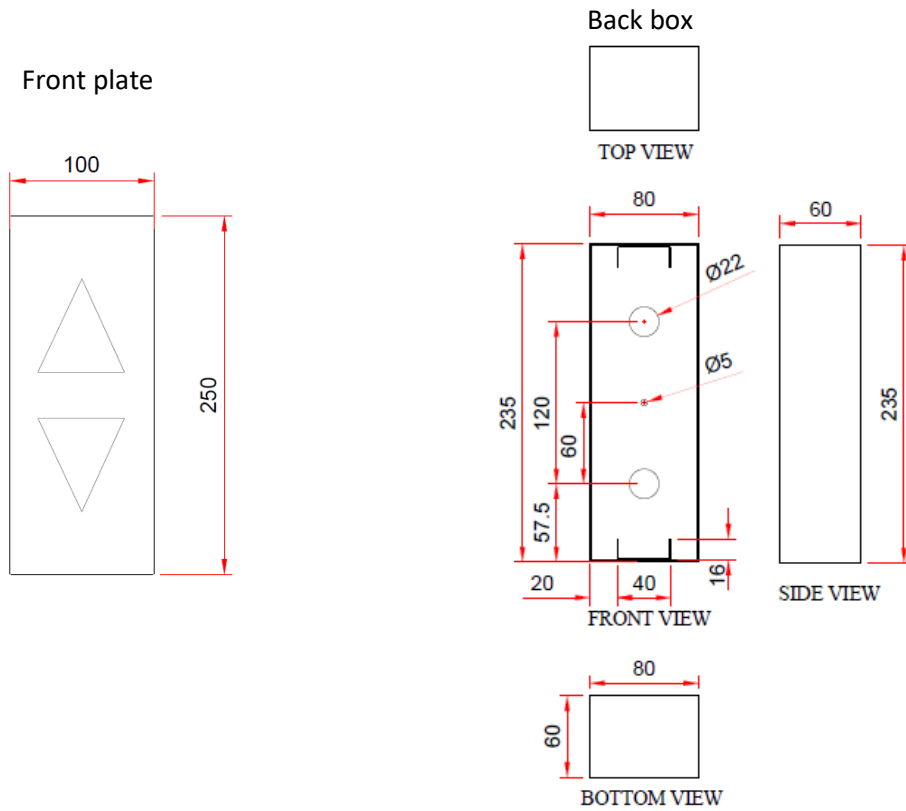

**CONNECTION DETAILS:**

